

# WÄRTSILÄ BIOGAS SOLUTIONS

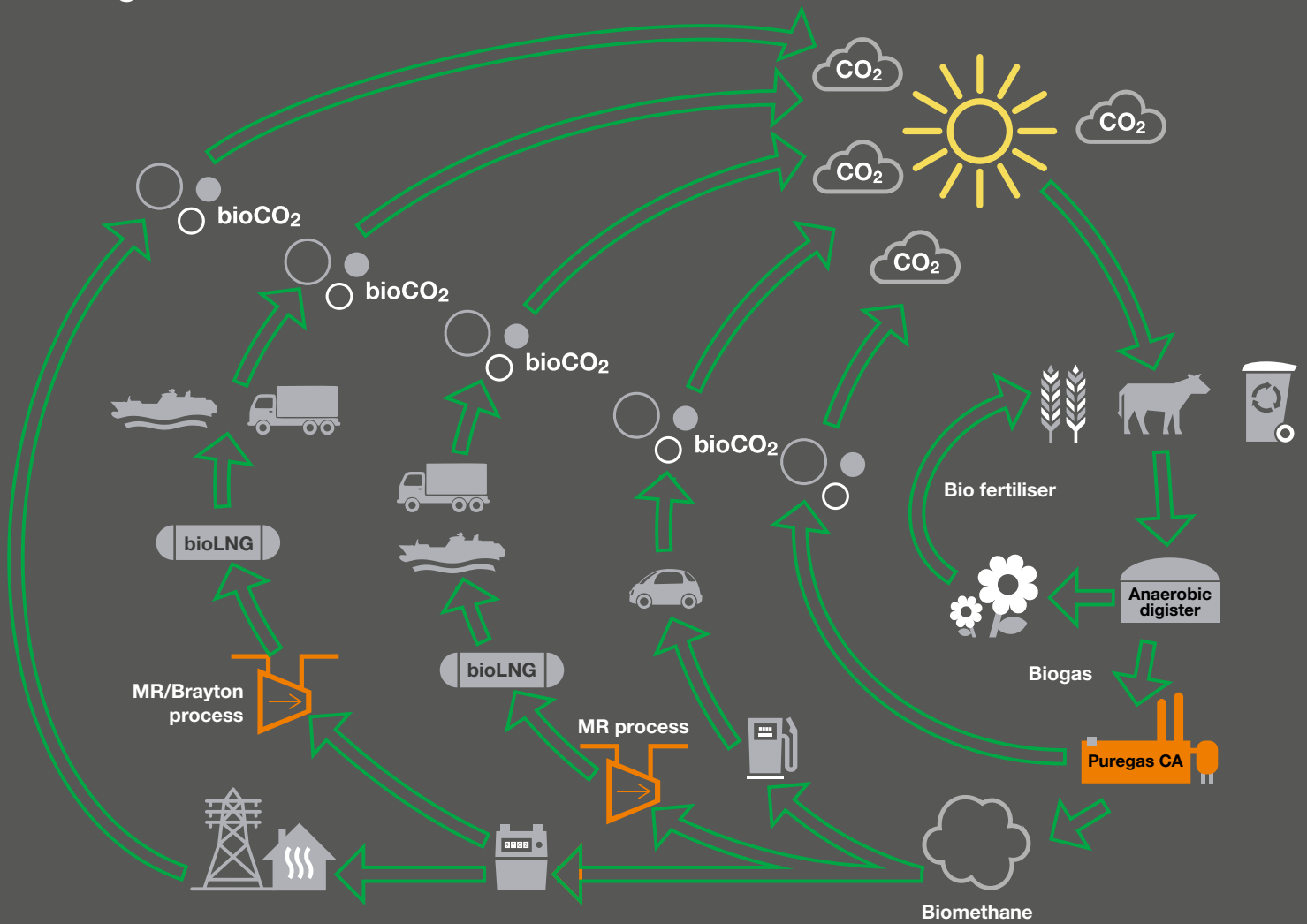

# Biogas – a circular business model



## Go forward, go circular!

Biomethane is part of a circular value chain from waste to valuable energy products. The circular biogas (biomethane) model does not only protect the climate and secure biodiversity but it also creates job

opportunities and helps to maintain energy security. Biomethane is a versatile fuel that can be used for heating, power production, energy storage and transport in both gas and liquid form.



# Fuelling our future

Upgraded biogas, (biomethane), has the same characteristics as natural gas. The difference is the origin.

Both natural gas and biomethane release carbon dioxide when combusted. Even though natural gas is the cleanest of the fossil fuels it adds carbon dioxide to the atmosphere, thus contributing to the climate change. The carbon dioxide from biomethane is part of a circular loop and the released carbon dioxide is absorbed by the growth of new biological feedstocks. The atmosphere's greenhouse gases can even be reduced when feedstocks like manure is used for producing biomethane instead of left untreated.

Biomethane and natural gas have the same chemical and technical characteristics. As such, biomethane can be injected to the natural gas grid and if liquified bioLNG can be mixed with LNG. Sharing the existing infrastructure with natural gas offers a safe, cost efficient and fast path towards decarbonize the gas system.

MS Visby, Gotlandsbolaget (ferry between mainland and island of Gotland) runs on a mixture of LNG and bioLNG.



# Lifecycle solutions

Wärtsilä offers solutions for upgrading biogas to biomethane and liquefaction of biomethane to bioLNG. The solutions are characterized by proven technologies and lowest operational costs supported by first-class project execution. Wärtsilä has served the biogas industry for over 20 years and have more than 45 references worldwide.

Biogas upgrading is based on the Puregas CA technology, an amine scrubber optimized for biogas and small-scale natural gas polishing. Thanks to its low methane slip and power consumption it does not only

offer the lowest operation costs but it also reduces the environmental footprint.

When liquefying the polished biomethane or grid gas it is cooled

down to -160 °C, for optimal CAPEX and OPEX combination two solutions are offered. A Mixed Refrigerant (MR) process is used for lower capacities while for higher capacities the Brayton process is the recommended choice.

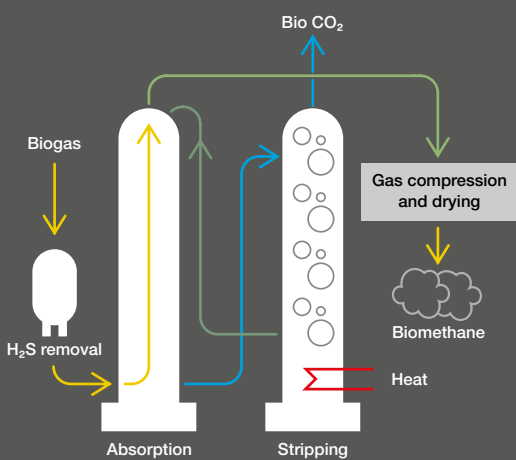

Puregas CA process

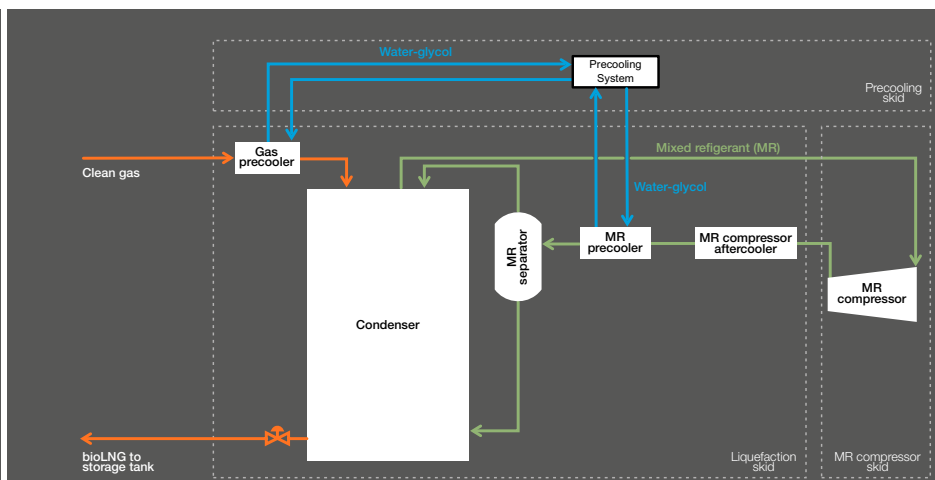

MR process

		Upgrading & Polishing capacity Puregas CA range in Nm <sup>3</sup> /h (raw biogas)							(Bio or Natural Gas)	
		700	1 300	2 000	3 000	4 500	6 000	12 000	12,000 - 30,000	
Upgrading (LBG model incl. polishing)	CA30	█								
	CA50	█								
	CA60	█								
	CA70	█								
	CA80	█					Dual			
Polishing	CAP25	█								
	CAP100	█								
	CAP Cust.	█								
		Liquefaction capacity in tons per day								
		6	10	17	25	50	100	100 - 300		
Liquefaction	MR6	█								
	MR10	█								
	MR17	█								
	MR25	█								
	MR50	█					Dual			
	Brayton	█								

Product ranges



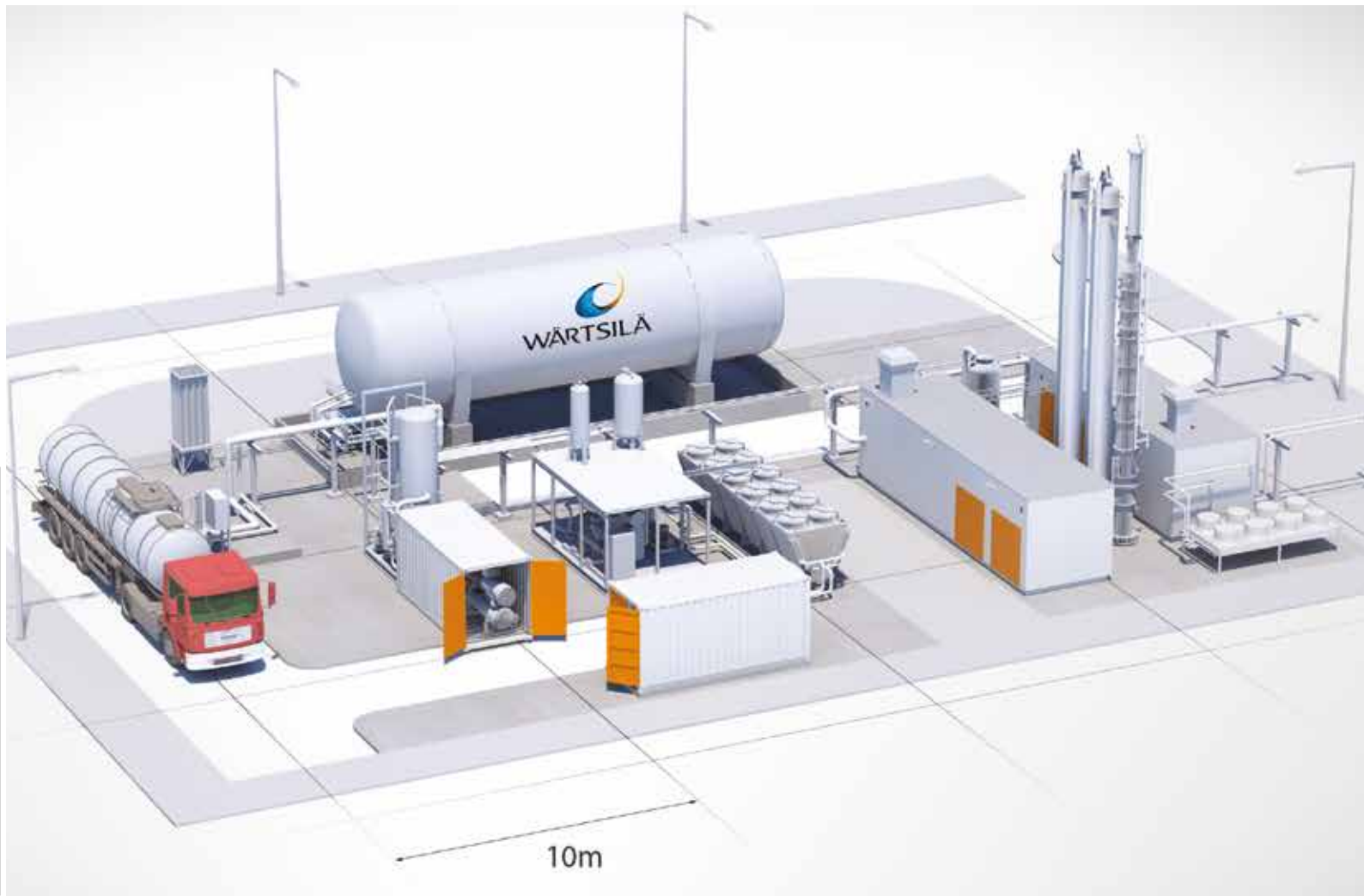

Example of Wärtsilä biogas liquefaction plant.



Veas, Norway's largest wastewater treatment plant, fundamental to keep the Oslo fiord clean. It is also an opportunity to produce biogas. The biogas is upgraded and liquefied with Wärtsilä Puregas CA and MR process producing carbon neutral liquid transport fuel for Oslo buses and other heavy transport vehicles



Sönderjysk biogas upgrading plant in Denmark with two Wärtsilä biogas upgrading plants model Puregas CA80, upgrading 10,000 Nm<sup>3</sup>/h of biogas

# Optimised plant performance and profitability

An investment in biogas upgrading and/or liquefaction is a long-term investment. Solutions that decarbonize the transport fuel sector at a low cost is key for profitability.

Wärtsilä offers effective Lifecycle cost solutions characterised by:

- Robust and proven process performance
- Lowest operational costs
- Secure and steady output of high-quality fuels

Wärtsilä turnkey plants operate with proven high uptime and performance

year after year. Processes have been continuously fine-tuned and improved based on real operational data and experience.

The single largest operational cost for upgrading and liquefaction is electricity. Wärtsilä offers the lowest electrical consumption for both upgrading and liquefaction. For upgrading, electricity consumption is less than half compared to other technologies.

Methane slip does not only result in loss of revenue, it is also a greenhouse gas emission. Liquefaction has a zero

methane slip and the methane slip from upgrading is a factor 10 to 60 lower compared to other technologies.

Both upgrading and liquefaction are based on closed loop processes which minimize the media consumption. Unlike some upgrading technologies, performance does not deteriorate over time and consistent results over the whole lifecycle of the plant can be achieved.

Biomethane injected to the grid or bioLNG to be mixed with LNG need to fulfil the required quality for e.g. energy

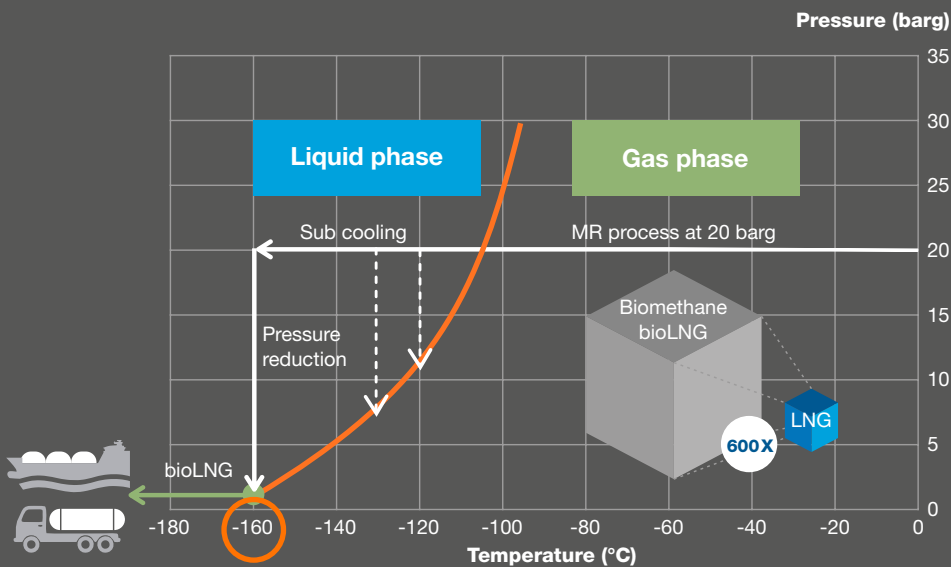

The bioLNG needs to be distributed from the production site to the refuelling station, moving the bioLNG from the storage tank to a tank-truck that off-load at to the refuelling station's storage tank. In order to secure the required temperature to its end users (trucks, ships etc) and being fully mixable with fossil LNG the bioLNG must be cooled down during liquefaction to the level of -155 to -165° C.

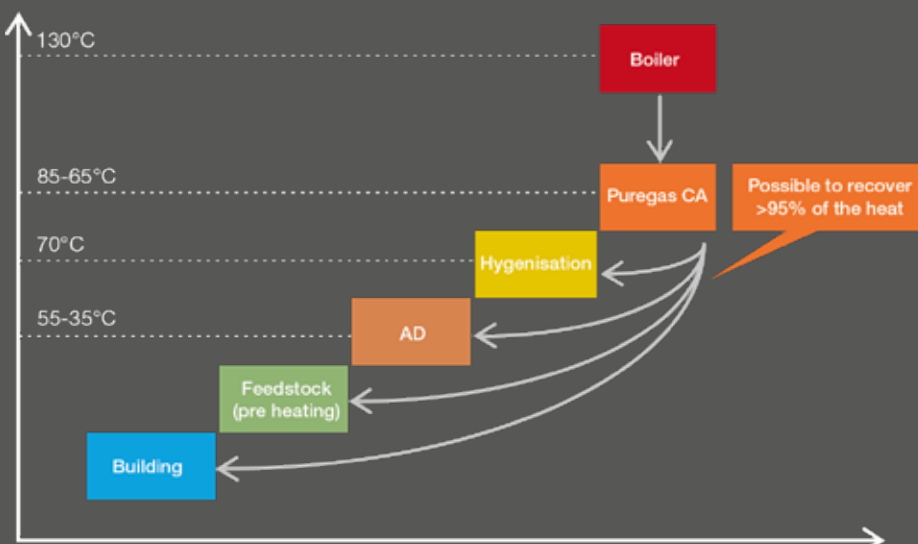

A biogas plant is in need of thermal heat for its anaerobic digestion process and in many cases for hygenisation of substrates. Other heating needs could be AD process heating, buildings and frost protection of surfaces: For those heating purposes heat can be recovered from the biogas upgrading plant, 95% of the heat can be recovered.



content, wobble index, temperature etc. Our solutions secure such quality directly from the process without any need for additional treatment or additives.

Wärtsilä fabricates all process modules for its biogas upgrading in their own facilities in Kalmar, Sweden. Components are based on standard

components as far as possible, for critical parts Wärtsilä have a close cooperation with its selected suppliers. To secure delivery quality and minimize installation time at site all process modules undergo Factory Acceptance Test (FAT) before being shipped to its destination.

## We are with you all the way – 24/7

Wärtsilä offers a wide range of services and solutions worldwide – lifecycle solutions, spare parts, technical

support, training and cyber services – to ensure that you get the most out of your asset throughout its lifetime.



**BIOKRAFT**



Assembly of process modules in Wärtsilä Kalmar plant

**Wärtsilä is a market leader in turnkey solutions for biogas upgrading and liquefaction and natural gas liquefaction plants. Wärtsilä Biogas Solutions is part of Wärtsilä Marine System's Gas Solutions. Wärtsilä Biogas Solutions has facilities and personnel in Norway, Sweden, Finland, Denmark, Germany, UK and USA, supported by Wärtsilä's global resources and network.**



[Wärtsilä Biogas Solutions](#)